



PROSeries

Installation Guide



Ford F-150



Watch the video

Info on Table of Contents page

Kits 93355 | 94355

For maximum effectiveness and safety, please read these instructions completely before proceeding with installation.

Failure to read these instructions can result in an incorrect installation.

Protect your Air Lift Purchase by Completing your Warranty Registration



Thank you for purchasing an Air Lift load support product!

Take a photo of your sales receipt and then scan the QR code to complete your online warranty registration.

TABLE OF CONTENTS

System Overview	2
Hardware and Tools	3
Introduction	4
Notation Explanation	4
Identifying the Difference Between Kits	4
Installing the System	5
Preparing the Vehicle	5
Installing the Air Lines	13
Installation Checklist	15
Maintenance and Use Guidelines	15
Limited Warranty and Return Policy	16

Video-enhanced installation guides

Visit airliftcompany.com/workshop/category/install-videos to access our installation video archive*.

System Overview

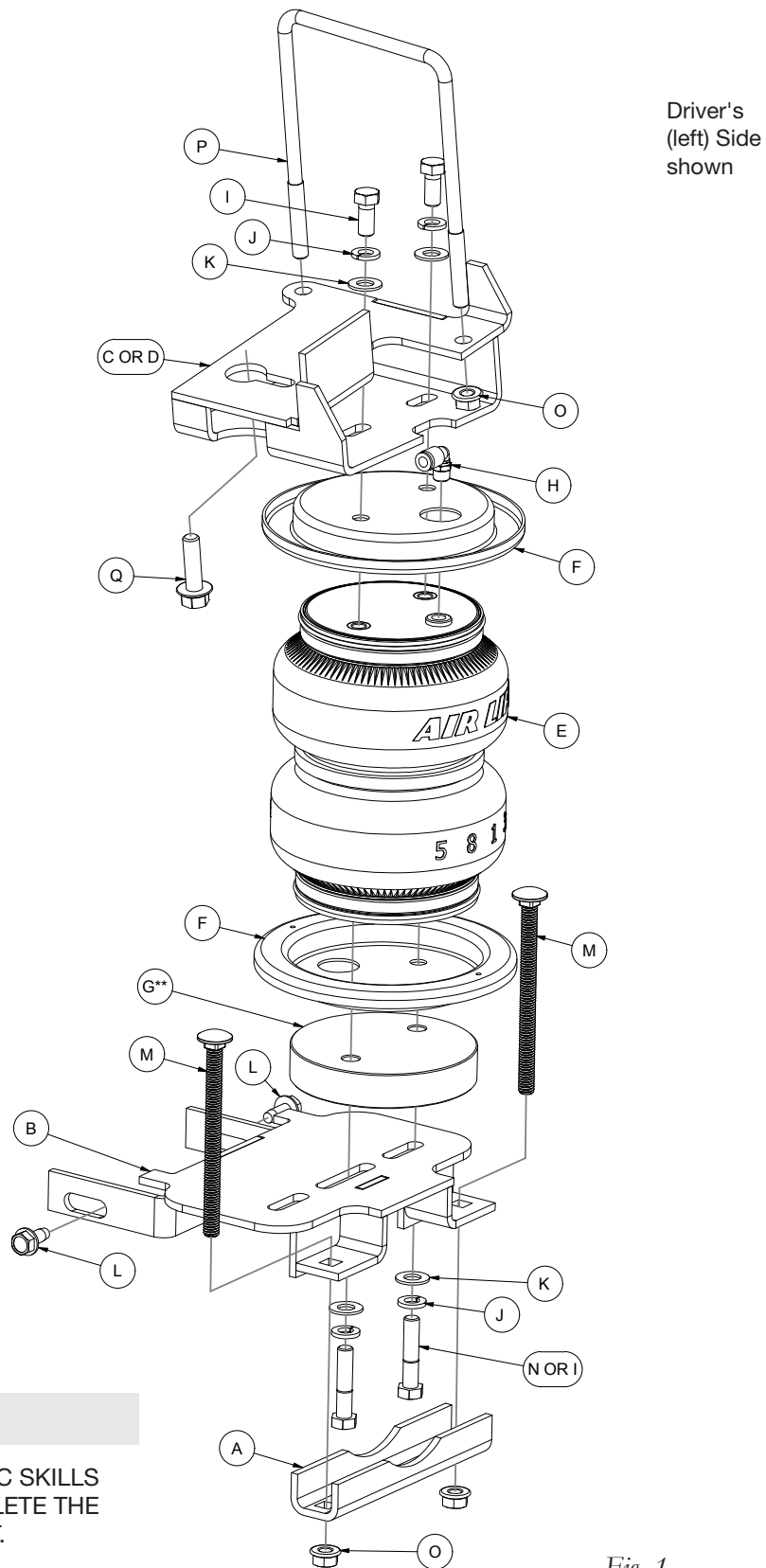

Driver's
(left) Side
shown

⚠ CAUTION

PROFESSIONAL MECHANIC SKILLS ARE REQUIRED TO COMPLETE THE INSTALLATION OF THIS KIT.

** Optional: May not be required for your installation. See page 7.

Fig. 1

Hardware and Tools

Common Parts Included in Both Kits

Item	Part#	Description	Qty
A	01531	Clamp bar	2
B	03977	Lower bracket	2
C	07555	Upper left bracket	1
D	07999	Upper right bracket	1
G**	11387	Lower spacer	2
H	21848	1/4" Air fitting	2
I	17284	3/8"-24 x 7/8" Stainless steel hex-head bolt	8
J	18504	3/8" Stainless steel lock washer	8
K	18507	3/8" Stainless steel flat washer	8
L	17102	5/16"-18 x 3/4" Self -threading screw	4
M	17168	3/8"-16 x 5" Carriage bolt	4
N	17585	3/8"-24 x 1.3/4" Stainless steel hex-head screw..	4
O	18422	3/8"-16 Serrated flange nut	8
P	11325	3/8"-16 U-bolt	2
Q	17268	M10-1.5 x 35mm Flange bolt	2
R*	11149	Left hand ABS wiring harness bracket	1

S*	11150	Right hand ABS wiring harness bracket	1
T*	17175	1/4"-20 x 3/4" Hex cap screw	1
U*	17187	3/8"-16 x 7/8" Hex cap screw	1
V*	18419	1/4" Flat washer	1
X*	18425	1/4" Nylon lock nut	1
Y*	18435	3/8" Nylon lock nut	1
Z*	18444	3/8" Flat washer	1
AA*	20086	Air line assembly	1
BB*	10466	Zip ties	6
CC*	18411	5/16" Lock washer	2
DD*	21234	Rubber washer	2
EE*	18501	M8 Flat washer	2
FF*	21233	5/16" Hex nut	2
GG*	21230	Valve cap	2
HH*	21838	Tee fitting	1

* These parts are not shown in the System Overview (Fig. 1).

Unique Parts in Each kit

Air lift **PROSeries**

KIT 93355

Item	Part#	Description	Qty
E	58937	Air spring	2
F	11951	Roll plate (silver zinc plated)	4

Air lift **PROSeries** ULTIMATE

KIT 94355

Item	Part#	Description	Qty
E	58996	Air spring	2
F	11967	Roll plate (black powder coat)	4

Tools Needed

Description	Qty
Standard and metric open-end or boxed wrenches	Set
Standard and metric regular and deep-well sockets	Set
Ratchet	1
Torque wrench	1
7/32" hex-key wrench (socket preferable)	1
Hose cutter, razor blade, or sharp knife	1
Cutoff wheel, air reciprocating saw or a hacksaw	1
Christmas tree puller	1
Hoist or floor jack	1
Safety stands	2
Safety glasses	1
Air compressor or compressed air source	1
Spray bottle with dish soap/water solution	1



Missing or damaged parts? Call Air Lift customer service at (800) 248-0892 for a replacement part.

Introduction

The purpose of this publication is to assist with the installation and maintenance of the Air Lift® ProSeries and ProSeries Ultimate air spring kits. All Air Lift® ProSeries and ProSeries Ultimate kits utilize sturdy, reinforced, commercial-grade single or double, depending on the kit, convolute bellows.

The air springs are manufactured like a tire with layers of rubber and cords that control growth. Air Lift® ProSeries and ProSeries Ultimate kits provide up to 5,000 pounds (2,268kg) of load-leveling support with air adjustability from 5-100 PSI (.34-7BAR).

It is important to read and understand the entire installation guide before beginning installation or performing any maintenance, service or repair.

NOTATION EXPLANATION

Hazard notations appear in various locations in this publication. Information which is highlighted by one of these notations must be observed to help minimize risk of personal injury or possible improper installation which may render the vehicle unsafe. Notes are used to help emphasize areas of procedural importance and provide helpful suggestions. The following definitions explain the use of these notations as they appear throughout this guide.

DANGER

INDICATES IMMEDIATE HAZARDS WHICH WILL RESULT IN SEVERE PERSONAL INJURY OR DEATH.

WARNING

INDICATES HAZARDS OR UNSAFE PRACTICES WHICH COULD RESULT IN SEVERE PERSONAL INJURY OR DEATH.

CAUTION

INDICATES HAZARDS OR UNSAFE PRACTICES WHICH COULD RESULT IN DAMAGE TO THE MACHINE OR MINOR PERSONAL INJURY.

IDENTIFYING THE DIFFERENCE BETWEEN KITS

Should you need to contact Air Lift customer service, you will need to know which kit you are inquiring about: standard Air Lift® ProSeries or Air Lift® ProSeries Ultimate. The kits are easily identifiable by looking at the roll plates.

- Standard **Air Lift® ProSeries** — Zinc-plated steel roll plates.
- Air Lift® ProSeries Ultimate** — Black powder-coated roll plates.



Air Lift® ProSeries
silver zinc-plated steel
roll plate



Air Lift® ProSeries Ultimate
black powder-coated roll plate

Installing the System

PREPARING THE VEHICLE

1. Lift the vehicle and support the frame with safety stands. Drop the axle down low enough to later set the air spring assemblies into position between frame and leaf spring (Fig. 2).

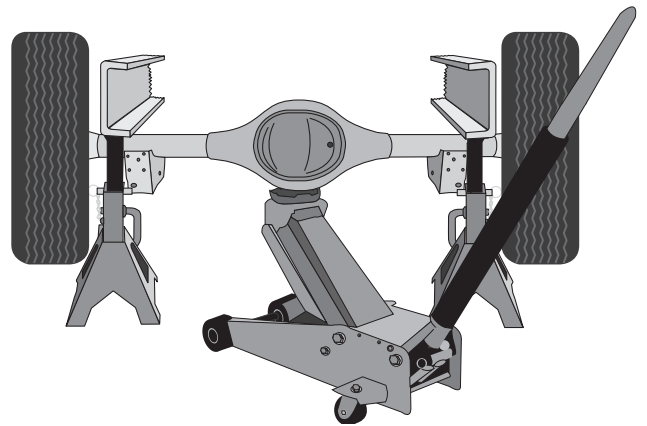

Fig. 2

2. Remove the factory jounce bumpers using a 13mm socket and an extension. The bolts have blue sealant on them and may require a small impact (Fig. 3).

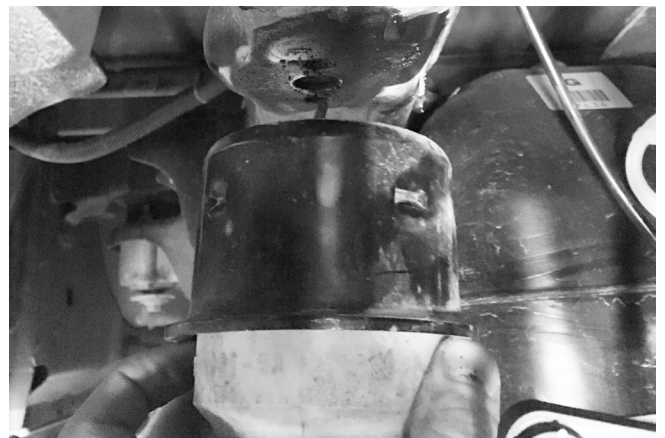

Fig. 3

3. Thread the included M10 flange head bolt (Q) into the locations created by the jounce bumpers. Leave approximately a 1/2" (13mm) gap between the bolt flange and the chassis (Fig. 4).



Fig. 4

4. Install the upper brackets (C-left or D-right) by pushing the bracket up against the frame so the flanged bolt passes through the keyway in the bracket. When the bracket is against the frame push the bracket outward to lock into the keyway. Tighten the flanged nut (O), making sure the vertical portion of the bracket is touching the side of the frame (Fig. 5). Torque bolt to 20 lb.-ft. (27Nm).

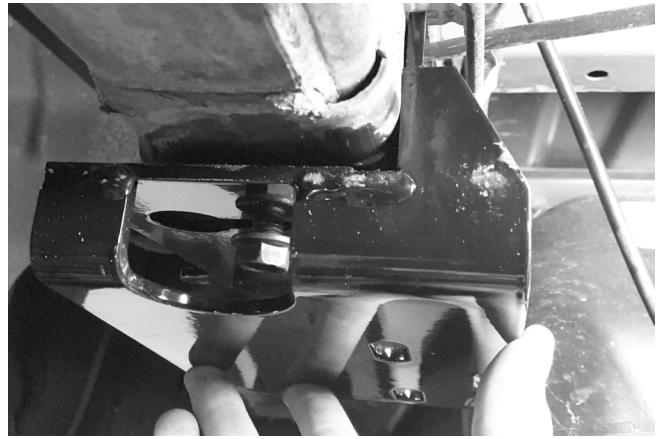

Fig. 5

5. Remove the brake line tabs attached to both sides of the leaf spring perches with a 10mm socket (Fig. 6). Remove the plastic clip from the ABS line on the right side of the axle (Fig. 7).

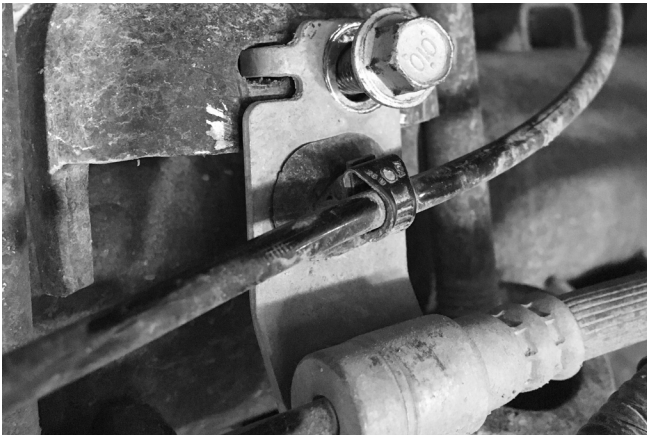

Fig. 6



Fig. 7

NOTE

On all trucks, a small portion of the brake line bracket needs to be cut for proper clearance to fit the lower bracket.

6. Pull up on the locking tab of the right-side connector and pull the connector off the ABS/Brake line axle junction bracket (Fig. 8). Pull the right side “cup” on the harness off the ABS/Brake axle junction bracket (Fig. 9). Pull the harness off the bracket and secure the harness out of the way for the next step.

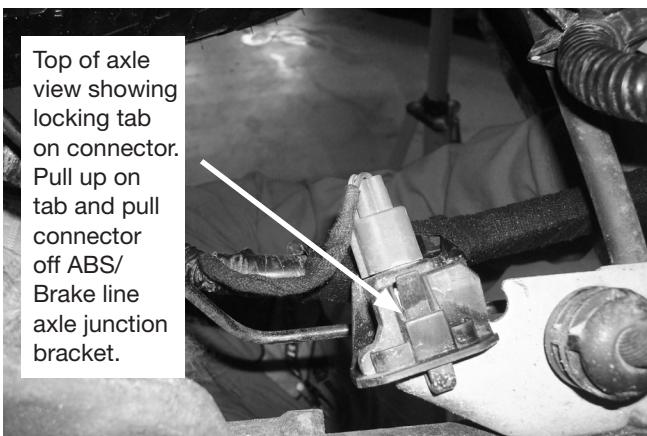

Fig. 8

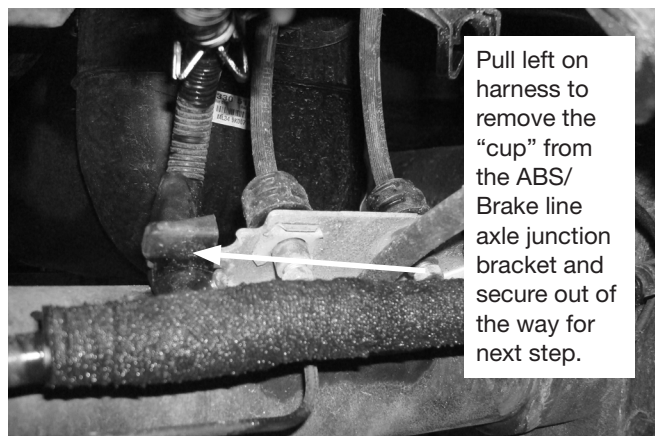

Fig. 9

⚠ CAUTION

USE CAUTION WHILE CUTTING THE BRAKE LINE BRACKET. ENSURE THE BRAKE LINE AND WIRE HARNESS HAVE PROPER CLEARANCE TO AVOID DAMAGE FROM THE SAW.

7. Measure approximately 1.375" (35mm) from the edge of the bracket, this may vary depending on the truck. Use the dashed line on Fig. 10 as a reference. Make the cut to the bracket using a cutoff wheel, air reciprocating saw or a hacksaw.

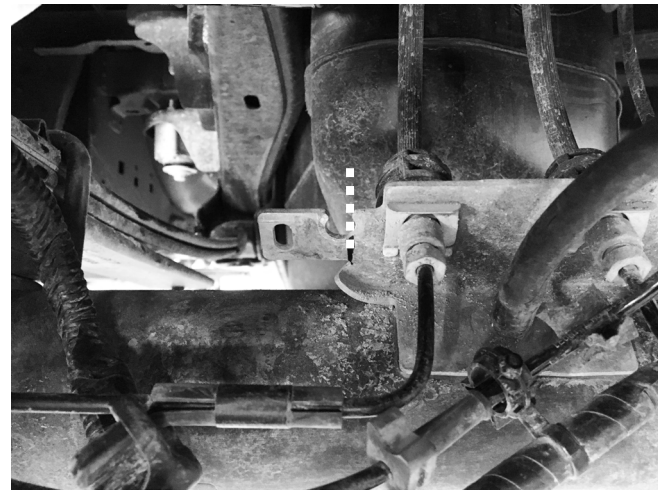

Fig. 10

8. Determine spacing between the upper and lower brackets by temporarily setting the lower bracket (B) into position and lower the body/frame of the truck so that it is sitting at ride height. Once the truck is at its natural ride height, measure the distance from the lower bracket to the upper bracket. Measure from the bottom mounting surface to the top mounting surface. If the measurement is 6.75" - 7.50" (171-191mm) the included spacer (G) will be required (Fig. 11).



Fig. 11

NOTE

The following photos show installation with the spacer. If your truck does not require the spacer, use the included shorter hardware (N).

- Place a carriage bolt (M) through the front hole on the lower brackets (Fig. 12). Flip the air spring (E) upside down (air fitting port down). Place the roll plate (F) (Fig. 13), spacer (G) (if required) (Fig. 14) and lower bracket (B) (Fig. 15) on the air spring, making sure all the holes are lined up. Thread the hex-head screw (N or I) with flat washer (K) and lock washer (J) finger-tight. Keep everything loose enough so that the air spring can slide front to back. Ensure the air fitting port on the air spring is facing inboard of the vehicle and that the air spring is mounted forward on the bracket. See diagrams below for clarity (Fig. 16). Flip the assemblies upright and install the air fittings (H) finger-tight plus 1 1/2 turns.



Fig. 12



Fig. 13



Fig. 14



Fig. 15



Fig. 16

10. Lift the truck and let the axle hang. Place the assemblies on the axle (Fig. 17) with the tabs wrapping around the leaf spring perch (Fig. 18). Install the included self-threading screw (L) and brake line tab on the spring perch (Fig. 18). On the front side, use the self-threading bolt to secure the front tab to the spring perch (Fig. 19).

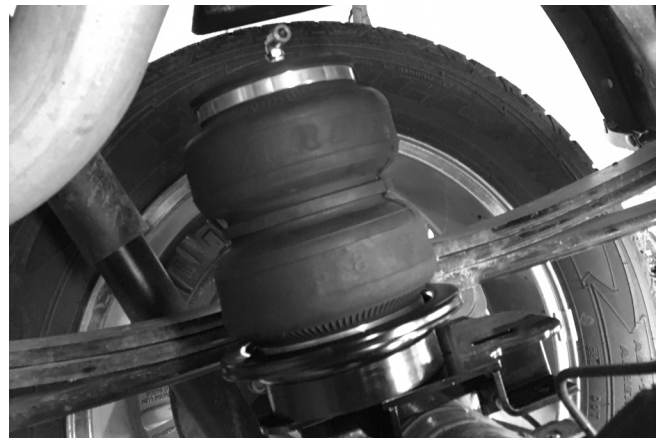

Fig. 17

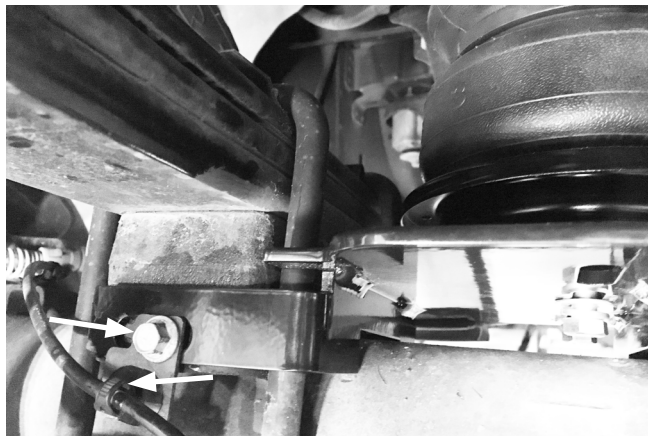

Fig. 18



Fig. 19

11. Install the remaining two carriage bolts onto the lower brackets (Fig. 20). Next, insert the clamp bars (A) over the carriage bolts with the serrated flange nuts (O) to attach the lower bracket assembly to the axle (Fig. 21). Torque to 16 lb.-ft. (22Nm).



Fig. 20



Fig. 21

12. Place the last two roll plates on top of the air springs, making sure the mounting holes are lined up with the threaded holes on the air spring (Fig. 22). Raise the axle enough to allow the top of the air spring to move around a little. There should only be about a 1/8" (3mm) gap between the top of the air spring assembly and the upper bracket (Fig. 23).



Fig. 22



Fig. 23

13. Install the mounting hardware (I, J, K) to attach the air spring to the upper bracket. Thread the hardware finger-tight (Fig. 24).



Fig. 24

⚠ CAUTION

ENSURE PROPER CLEARANCE BETWEEN THE U-BOLT AND THE BRAKE LINES TO PREVENT DAMAGE TO THE BRAKE LINES.

14. Place the U-bolt (P) over the top of the frame and pass the ends through the two holes on the front side of the upper bracket. Thread serrated flange nuts on both sides and torque to 10 lb.-ft. (14Nm) (Fig. 25).



Fig. 25

15. Raise the axle all the way up, then align the air spring by sliding the assembly forward or backward. Ensure clearance to objects around the air spring and torque the mounting hardware on the top and bottom to no more than 20 lb.-ft. (27Nm) (Fig. 26).



Fig. 26

⚠ CAUTION

ENSURE PROPER CLEARANCE AWAY FROM SHARP EDGES AND COMPONENTS TO PREVENT DAMAGE TO THE WIRING HARNESS AND ABS LINE.

16. Insert the left-hand ABS wiring harness bracket (R) into the “cup” of the ABS wiring harness and secure to the lower bracket (B) with 3/8"-16 X 7/8" hex cap screw (U), 3/8" flat washer (Z), and 3/8" nylon lock nut (Y) (Fig. 27 & Fig. 28). Tighten securely.



Fig. 27

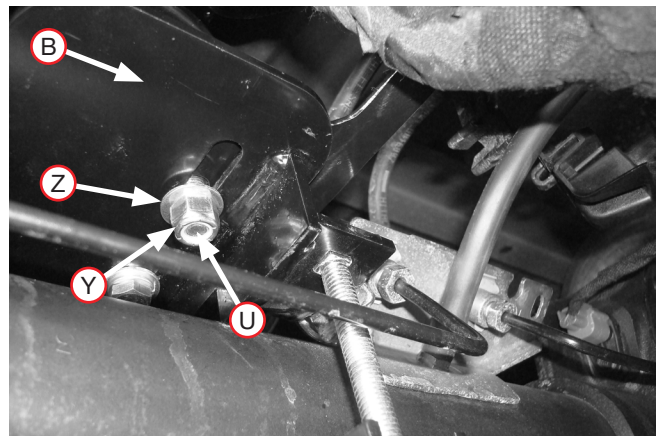

Fig. 28

17. Install the right-hand wiring harness connector onto the right-hand wiring harness bracket (S), making sure the locking tab locks the connector into position (Fig. 29). Secure to the ABS/Brake line axle junction bracket with 1/4"-20 X 3/4" hex cap screw (T), 1/4" flat washer (V), and 1/4" nylon lock nut (X) (Fig. 30). Tighten securely.

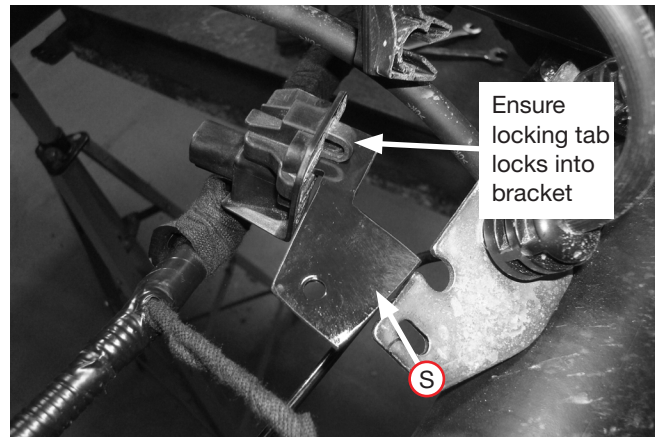

Fig. 29

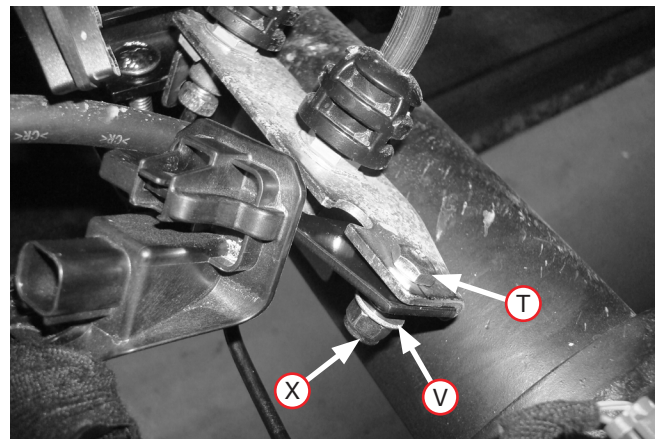

Fig. 30

18. Fig. 31 shows a finished photo of how the ABS wiring harness is secured.

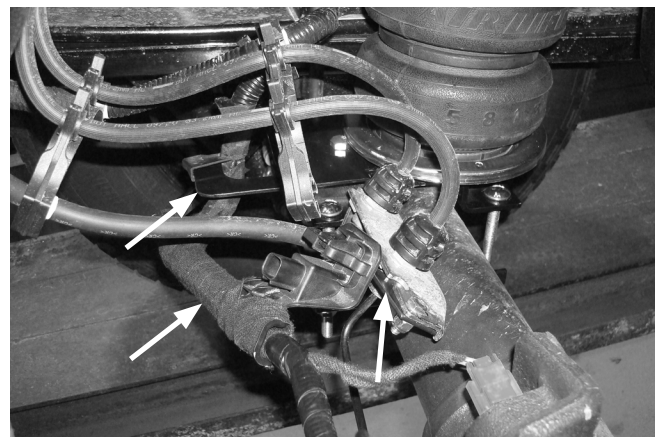
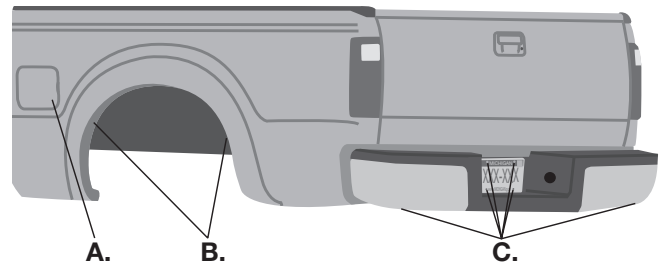

Fig. 31

Installing the Air Lines

1. Choose the locations for the Schrader valves and drill a 5/16" (8mm) hole, if necessary (Fig. 32).
2. An optional tee fitting (HH) has been supplied for those who prefer to use just one Schrader fill valve on the vehicle.



A. Inside fuel tank filler door
 B. Inside rear wheel wells
 C. License plate or rear bumper area

Fig. 32

3. Cut the air line in half. Make clean, square cuts with a razor blade or hose cutter (Fig. 33). Do not use scissors or wire cutters.

CAUTION

KEEP AT LEAST 6" (152MM) OF CLEARANCE BETWEEN ALL AIR LINES AND THE EXHAUST SYSTEM. AVOID SHARP BENDS AND EDGES.

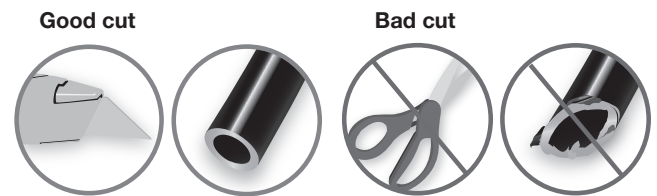

Fig. 33

4. Use zip ties to secure the air line to fixed points along the chassis. Do not pinch or kink the air line. Leave at least 2" (51mm) of slack in the air line to allow for any movement that might pull on the air line. The minimum bend radius for the air line is 1" (25mm).
5. Install the Schrader valve in the chosen location (Fig. 34).

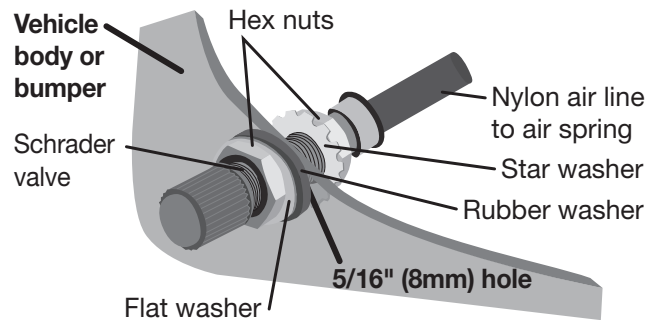

Fig. 34

INSTALLATION CHECKLIST

- Clearance test** — Inflate the air springs to 40-60 PSI (2.8-4.1BAR) and make sure there is at least 1/2" (13mm) clearance from anything that might rub against each sleeve. Be sure to check the tire, brakes, frame, shock absorbers and brake cables.
- Leak test before road test** — Inflate the air springs to 40-60 PSI (2.8-4.1BAR) and check all connections for leaks. All leaks must be eliminated before the vehicle is road tested.
- Heat test** — Be sure there is sufficient clearance from heat sources, at least 6" (152mm) for air springs and air lines. If a heat shield was included in the kit, install it. If there is no heat shield, but one is required, call Air Lift customer service at (800) 248-0892.
- Fastener test** — After 500 miles (800km), recheck all bolts for proper torque.
- Road test** — The vehicle should be road tested after the preceding tests. Inflate the air springs to recommended driving pressures. Drive the vehicle 10 miles (16km) and recheck for clearance, loose fasteners and air leaks.
- Operating instructions** — If professionally installed, the installer should review the operating instructions with the owner. Be sure to provide the owner with all of the paperwork that came with the kit.

MAINTENANCE AND USE GUIDELINES

1. Check air pressure weekly.
2. Always maintain normal ride height. Never inflate beyond 100 PSI (7BAR).
3. If the system develops an air leak, use a soapy water solution to check all air line connections and the inflation valve core before deflating and removing the air spring.
4. Upon successful completion of the installation, follow these pressure requirements for the air springs.



CAUTION

FOR SAFETY AND TO PREVENT POSSIBLE DAMAGE TO THE VEHICLE, DO NOT EXCEED MAXIMUM GROSS VEHICLE WEIGHT RATING (GVWR) OR PAYLOAD RATING, AS INDICATED BY THE VEHICLE MANUFACTURER. ALTHOUGH THE AIR SPRINGS ARE RATED AT A MAXIMUM INFLATION PRESSURE OF 100 PSI (7BAR), THE AIR PRESSURE ACTUALLY NEEDED IS DEPENDENT ON LOAD AND GROSS VEHICLE WEIGHT RATING.

Notes

Limited Warranty and Return Policy

Air Lift Company provides a limited lifetime warranty to the original purchaser of its load support products, that the products will be free from defects in workmanship and materials when used on cars and trucks as specified by Air Lift Company and under normal operating conditions, subject to the requirements and exclusions set forth in the full Limited Warranty and Return Policy that is available at www.airliftcompany.com/warranty.

For additional warranty information contact Air Lift Company customer service.



Thank you for purchasing Air Lift Products — the Authorized Installer's choice!

Need Help?

Contact Air Lift Company Customer Service at (800) 248-0892
or email service@airliftcompany.com.

For calls outside the U.S. or Canada, dial (517) 322-2144.



MADE IN USA
WITH GLOBAL
COMPONENTS

Air Lift Company • 2727 Snow Road • Lansing, MI 48917 or P.O. Box 80167 • Lansing, MI 48908-0167

Air Lift Company reserves the right to make changes and improvements to its products and publications at any time.
For the latest version of this manual, contact Air Lift Company at (800) 248-0892 or visit airliftcompany.com.