

# LoadLIFTER™ 5000

by AIR LIFT®

## Kit 57365 Dodge Ram 1500 2 & 4-Wheel Drive

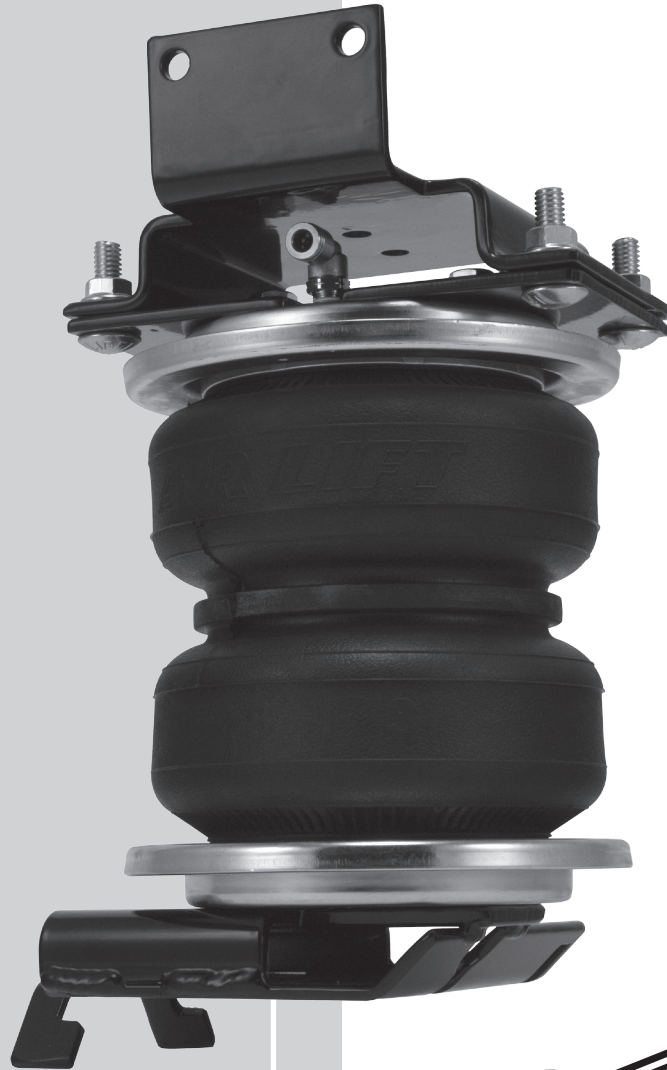

## INSTALLATION GUIDE

For maximum effectiveness and safety, please read these instructions completely before proceeding with installation.

*Failure to read these instructions can result in an incorrect installation.*



# TABLE OF CONTENTS

<b>Introduction</b> . . . . .	<b>2</b>
Important Safety Notice . . . . .	2
Notation Explanation . . . . .	2
<b>Installation Diagram</b> . . . . .	<b>3</b>
Hardware List . . . . .	4
Tools List . . . . .	4
<b>Installing the LoadLifter 5000 System.</b> . . . . .	<b>4</b>
Getting Started . . . . .	4
Assembling the Air Springs . . . . .	9
Installing the Assemblies . . . . .	11
<b>Installing the Air Lines</b> . . . . .	<b>14</b>
Tips for Installing Air Lines . . . . .	16
Installing the Heat Shield . . . . .	16
<b>Finished Installation Photos.</b> . . . . .	<b>17</b>
<b>Before Operating.</b> . . . . .	<b>18</b>
Checking for Leaks . . . . .	18
Fixing Leaks . . . . .	18
Installation Checklist . . . . .	19
Post-Installation Checklist . . . . .	19
<b>Product Use, Maintenance and Servicing</b> . . . . .	<b>20</b>
Minimum and Maximum Pressure . . . . .	20
Maintenance Guidelines . . . . .	20
Tuning the Air Pressure . . . . .	21
Guidelines for Adding Air . . . . .	21
<b>Troubleshooting Guide</b> . . . . .	<b>22</b>
Frequently Asked Questions . . . . .	22
<b>Limited Warranty and Returns Policy</b> . . . . .	<b>25</b>
<b>Replacement Part Information</b> . . . . .	<b>25</b>
<b>Contact Information</b> . . . . .	<b>25</b>

# Introduction

The purpose of this publication is to assist with the installation, maintenance and troubleshooting of the LoadLifter 5000 air spring kit. LoadLifter 5000 utilizes sturdy, reinforced, commercial grade single or double, depending on the kit, convolute bellows. The bellows are manufactured like a tire with layers of rubber and cords that control growth. LoadLifter 5000 Ultimate kits are recommended for most 3/4- and 1-ton pickups and SUVs with leaf springs and provide up to 5,000 pounds of load leveling support with air adjustability from 5-100 PSI.

It is important to read and understand the entire installation guide before beginning installation or performing any maintenance, service or repair. The information here includes a hardware list, tool list, step-by-step installation information, maintenance guidelines and operating tips.

Air Lift Company reserves the right to make changes and improvements to its products and publications at any time. For the latest version of this manual, contact Air Lift Company at **(800) 248-0892** or visit [airliftcompany.com](http://airliftcompany.com).

## IMPORTANT SAFETY NOTICE

The installation of this kit does not alter the gross vehicle weight rating (GVWR) or payload of the vehicle. Check your vehicle's owner's manual and do not exceed the maximum load listed for your vehicle.

**Gross vehicle weight rating:** The maximum allowable weight of the fully loaded vehicle (including passengers and cargo). This number — along with other weight limits, as well as tire, rim size and inflation pressure data — is shown on the vehicle's Safety Compliance Certification Label.

**Payload:** The combined, maximum allowable weight of cargo and passengers that the truck is designed to carry. Payload is GVWR minus the base curb weight.

## NOTATION EXPLANATION

Hazard notations appear in various locations in this publication. Information which is highlighted by one of these notations must be observed to help minimize risk of personal injury or possible improper installation which may render the vehicle unsafe. Notes are used to help emphasize areas of procedural importance and provide helpful suggestions. The following definitions explain the use of these notations as they appear throughout this guide.



**DANGER**

INDICATES IMMEDIATE HAZARDS WHICH WILL RESULT IN SEVERE PERSONAL INJURY OR DEATH.



**WARNING**

INDICATES HAZARDS OR UNSAFE PRACTICES WHICH COULD RESULT IN SEVERE PERSONAL INJURY OR DEATH.



**CAUTION**

INDICATES HAZARDS OR UNSAFE PRACTICES WHICH COULD RESULT IN DAMAGE TO THE MACHINE OR MINOR PERSONAL INJURY.

## NOTE

*Indicates a procedure, practice or hint which is important to highlight.*

# Installation Diagram

Left-hand side shown  
(driver side)

Right-hand side shown  
(passenger side)

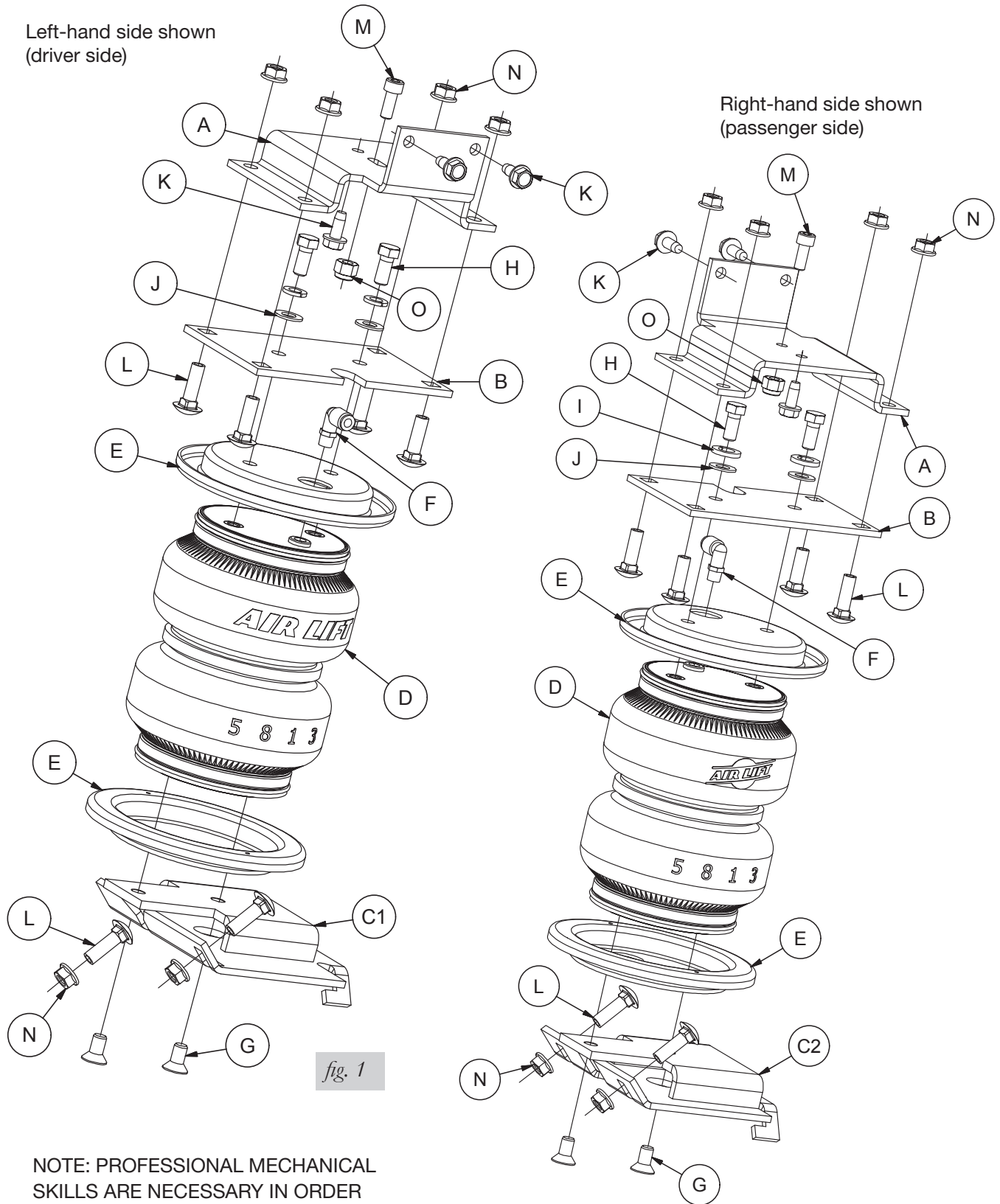

NOTE: PROFESSIONAL MECHANICAL SKILLS ARE NECESSARY IN ORDER TO COMPLETE THE INSTALLATION OF THIS KIT.

## HARDWARE LIST

Item	Part #	Description.....Qty	Item	Part #	Description.....Qty
A	07061	Frame bracket.....2	M	17495	M8-1.25 x 20 socket head screw .....2
B	07150	Air spring bracket.....2	N	18422	3/8"-16 serrated lock nut.....12
C1	03017	L.H. lower bracket.....1	O	18522	M8-1.25 nylon nut.....2
C2	03112	R.H. lower bracket .....1	AA*	20086	Air line assembly.....1
D	58437	Air spring.....2	BB*	10466	Tie strap.....6
E	11951	Roll plate.....4	CC*	21230	Valve cap.....2
F	21837	90° swivel fitting.....2	DD*	18501	5/16" flat washer.....2
G	17215	3/8"-24 x 3/4" flat head screw.....4	EE*	21234	Rubber washer.....2
H	17203	3/8"-24 x 7/8" hex head bolt .....4	FF*	18411	Star washer.....2
I	18427	3/8" lock washer.....4	GG*	21233	5/16" hex nut .....4
J	18444	3/8" flat washer.....4			
K	17102	5/16"-18 x 3/4" self-tapping screw.....6			
L	17361	3/8"-16 x 1.25" Carriage Bolt .....12			

\*Not shown in fig. 1.



Missing or damaged parts? Call Air Lift customer service at (800) 248-0892 for a replacement part.

## TOOLS LIST

Description..... Qty	Description..... Qty
Hoist or floor jacks ..... 1	7/32 allen wrench (socket if available)..... 1
Safety stands..... 2	1/4" and 5/16" drill bits (very sharp)..... 1
Safety glasses ..... 1	Heavy duty drill..... 1
4" grinder or metal cutting tool ..... 1	Hose cutter, razor blade, or sharp knife ..... 1
Torque wrench..... 1	Air compressor or compressed air source ..... 1
Standard open-end combo wrenches..... 1	Spray bottle with dish soap/water solution..... 1
Ratchet..... 1	Black paint or undercoating ..... 1
Metric and standard sockets..... 1	

# Installing the LoadLifter 5000 System

## GETTING STARTED

In order to install the upper frame brackets (A), it will be necessary to remove the coil springs as follows:

1. Lift the vehicle up and support the frame with jack stands. Leave enough room to drop the axle down low enough to remove the coil springs (Fig. 2). Remove the rear wheels.



fig. 2

2. Mark the bottom of the right-hand and left-hand coil springs and lower spring seat mounts with chalk or a paint marker to make sure the spring is put back the same way it is removed (Fig. 3).



*fig. 3*

3. Remove both lower shock bolts and slowly lower the axle until the springs can be removed.

**NOTE**

*Lower the axle carefully and avoid putting stress on the flexible brake lines.*

4. Remove both jounce bumpers from both sides (Fig. 4).



*fig. 4*

5. Grind the welds off the jounce bumper cups that attach them to the jounce bumper frame bracket (Fig. 5). Remove and discard from both sides of the vehicle.



*fig. 5*

6. Grind the welds removed, down flush to the frame with the grinder. (Fig. 6).

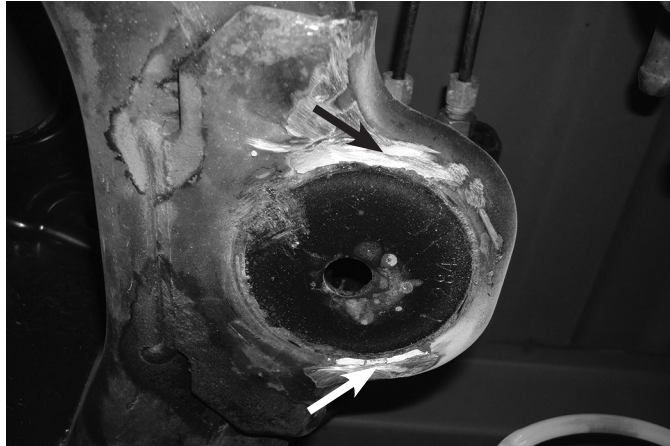
*fig. 6*

7. Spray the frame with black paint or undercoating to cover the bare surface, from grinding the welds flush previously (Fig. 7). Repeat for both sides.

*fig. 7*

8. Install the socket head M8 bolt (M) into the frame bracket (A) slot closest to the flange on the bracket (Fig. 8). Note: The head points in the same direction as the flange on the bracket. Cap with the nylon lock nut (O) as shown (Fig. 9).

*fig. 8*



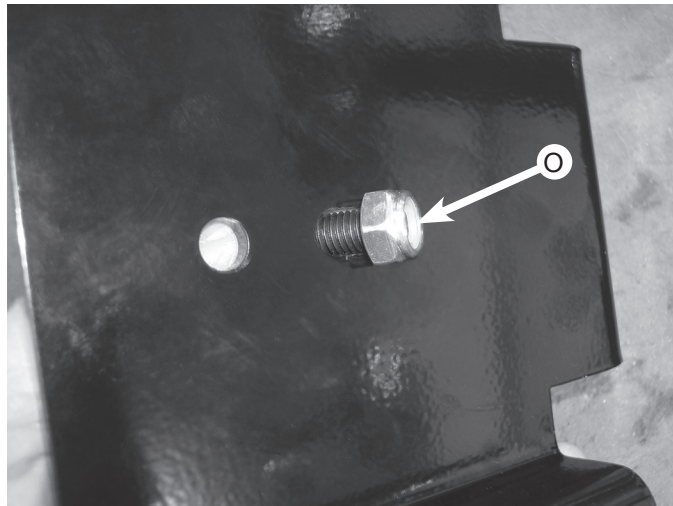

fig. 9

9. Only tighten the bolt to where it can still slide in the slot.
10. Set the frame bracket (with the socket head bolt in it), on the frame, with the flange pointing up. Insert the socket head bolt into the existing hole in the frame that was under the stock jounce bumper (Fig. 10).

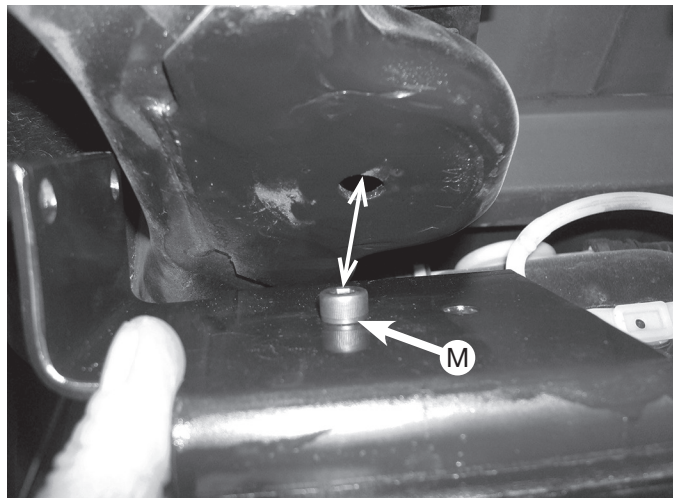

fig. 10

11. The bracket should sit flush to the bottom of the frame. If there is any leftover weld holding the bracket off the frame, remove and grind down so the bracket is flush.
12. With the socket head bolt in the hole, push the flange against the side of the frame (Fig. 11) and mark the existing hole under the frame with a paint marker (Fig. 12).

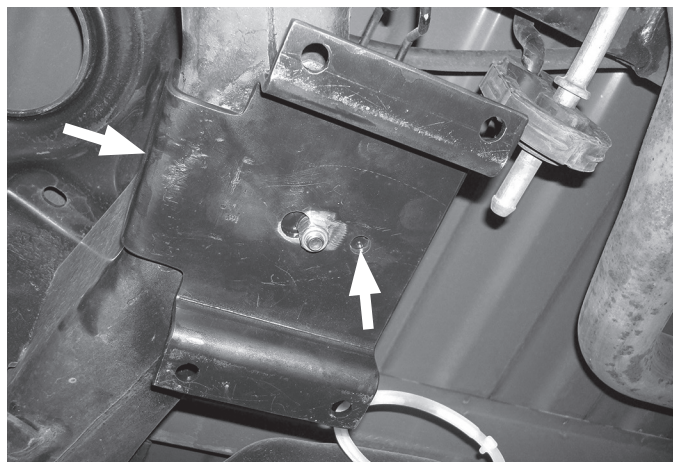

fig. 11

**TECHNICAL NOTE**

If possible, with the bracket in position, use a 21/64 (or closest) centering punch to fit into the hole and center-punch the frame for an exact center of the hole.

*fig. 12*

13. Center-punch the frame and drill a 1/4" hole (Fig. 13). Start a 5/16" self-tapping screw (K) into the hole, making sure it is straight, and tighten it enough to form the threads needed to set the screw (Fig. 13). Remove the screw once threads are formed. Repeat for both sides.

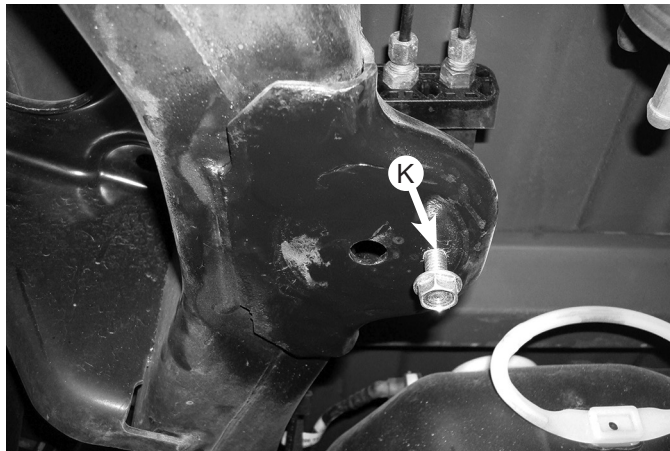
*fig. 13*

14. Set the bracket back in place on the frame and bolt into position using the self-tapping screw previously set into the frame. Tighten the screw making sure the washer head portion of the screw is flat to the bracket, and torque to 15 lb.-ft.
15. Make sure the bracket is flat to the bottom on the frame, center punch and drill through the frame with a 1/4" bit using the holes in the side of the flange as a guide (Fig. 14).

*fig. 14*

16. Install two more self-tapping screws (K) in the side, making sure the flat head portion of the bolt is flush to the bracket, and torque to 15 lb.-ft. (Fig. 15). Repeat for the other side.



Driver-side bracket shown mounted in place and ready for the air spring assembly.

fig. 15

17. Once the frame brackets have been installed on both sides, the stock suspension can be put back together.
18. Set the coil springs back into position using the index marks from the previous step and raise the axle back up making sure the spring indexes into the top and bottom spring seats correctly.
19. Install the wheels back on the axle and lower the vehicle back down so the wheels rest on the ground. Torque the lug nuts to the manufacturers torque specs.
20. Install the lower shock bolts back onto the axle and torque to 135Nm (100 lb.-ft.).

## ASSEMBLING THE AIR SPRINGS

1. Set a roll plate (E) onto the air spring (D).

### NOTE

*The radius (rounded) edge of the roll plate (E) will be towards the air spring, so that the air spring is seated inside both roll plates.*

2. Install the swivel fitting (F) into the top of the air spring finger-tight plus one-and-a-half turns (Fig. 16). Repeat for both air springs.

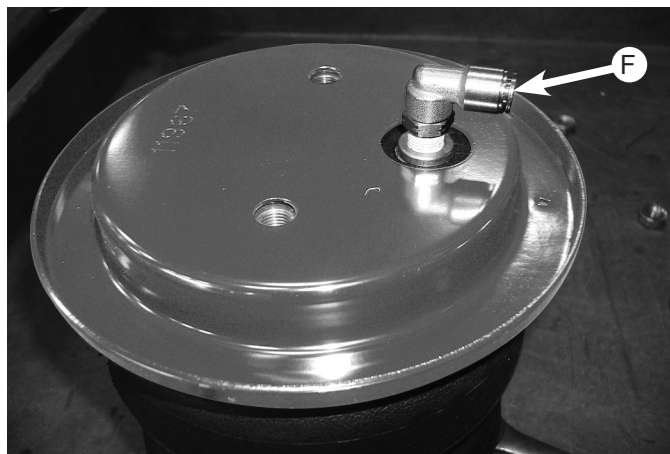
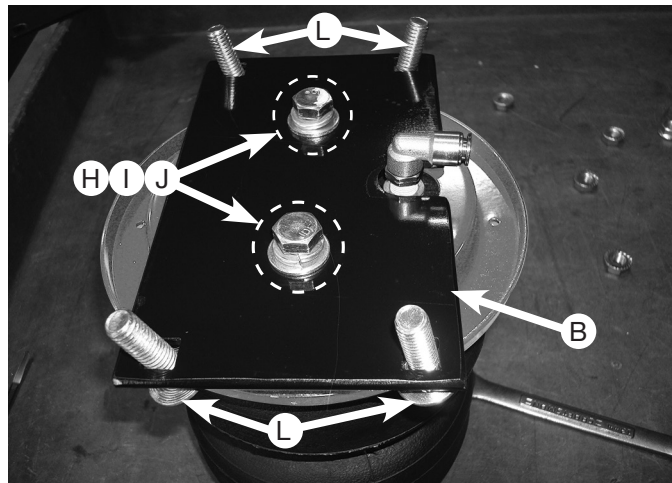
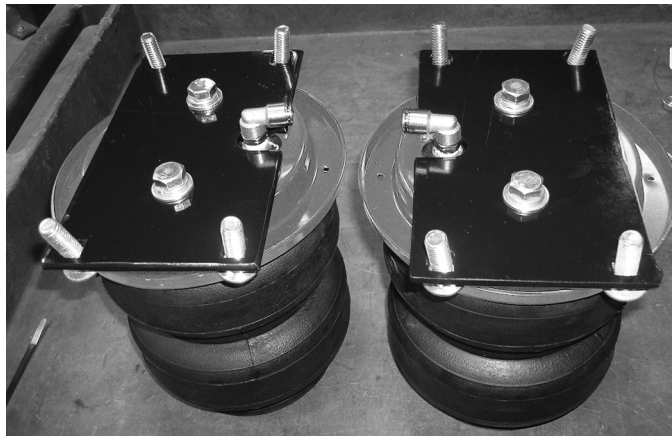

fig. 16

3. Insert four carriage bolts (L) into the upper air spring bracket (B) and set the upper bracket onto the air spring assembly (Fig. 17).
4. Attach the upper air spring bracket using two 3/8" hex head bolts (H), two lock washers (I) and two flat washers (J). Torque to no more than 20 lb.-ft. Repeat for the opposite side. Both upper assemblies shown in Figure 18.

*fig. 17*

*fig. 18*

5. Flip the air spring assemblies upside down and set a roll plate (E) over the air spring (same as in step one).
6. Position the air spring assemblies so that the fittings are outboard and away from each other (Fig. 19).

*fig. 19*
**NOTE**

*The finished assemblies will be left and right-hand specific, and the fittings that are on the top of the air springs should be facing the outside (tire side) of the vehicle once into position.*

7. Set the left-hand lower bracket (C1) onto the left side assembly (your left-hand facing both assemblies) and attach with two 3/8" flat head screws (G). Torque to no more than 20 lb.-ft. (Fig. 19). Attach the right-hand lower bracket (C2) onto the right-side assembly (your right-hand facing both assemblies). Attach with two 3/8" flat head screws (G). Torque to no more than 20 lb.-ft. (Fig. 20).

Left side assembly (driver side) using Lower Bracket (C1).



Right- side assembly (passenger side) using lower bracket (C2).

fig. 20

### INSTALLING THE ASSEMBLIES

1. Index a 3/8" carriage bolt (L) into the opening on the front of the driver side assembly as shown (Fig. 21).

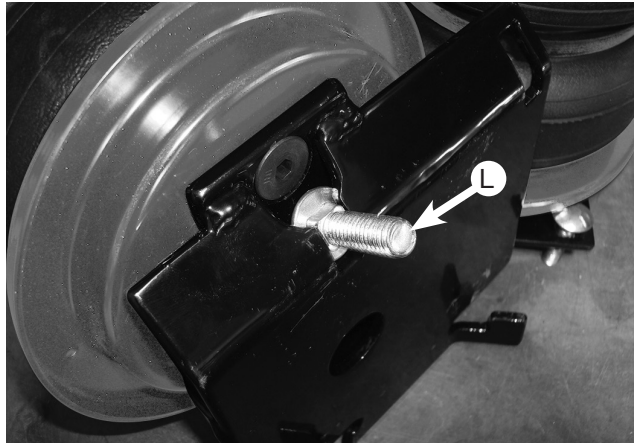
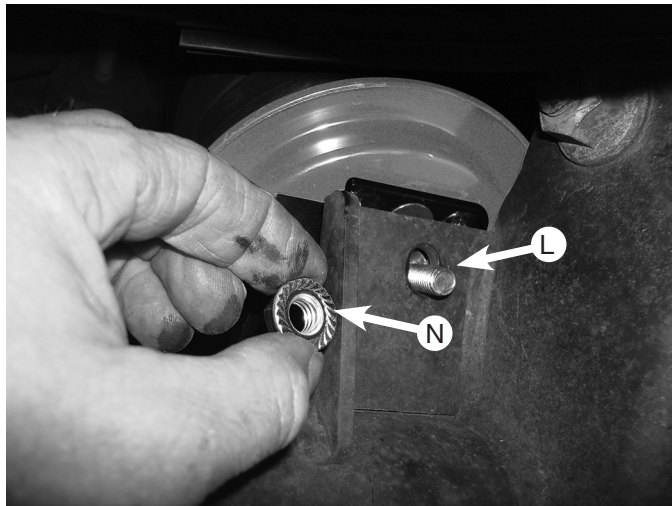

fig. 21

2. Drop the axle again to gain clearance to put the two assemblies into position on the axle.
3. Set the driver side assembly into position with the carriage bolt still in the slot (previously installed). Set into place on the axle making sure the back of the bracket is "hooked" below the jounce bumper strike plate. Push the assembly forward while lining up the carriage bolt with the existing hole in the front of the lower jounce bumper strike plate (Figs. 22 and 23). Cap the carriage bolt with a 3/8" serrated lock nut (N), but leave loose at this time.



fig. 22

*fig. 23*

4. Insert another 3/8" carriage bolt (L) through the remaining hole in the front side of the bracket (Fig. 24).

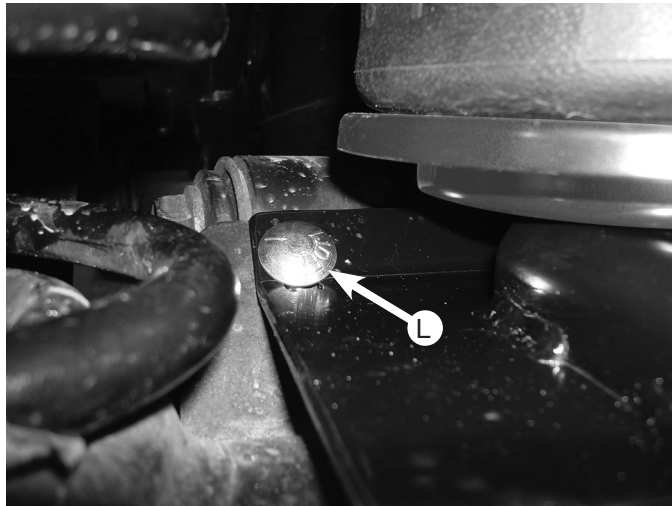
*fig. 24*

5. It will be necessary to use a socket with an extension to reach the inside threads on the carriage bolt previously set into position (Fig. 25). It may be helpful to pull the carriage bolt out slightly so that it can be angled enough to get started on the thread.



Use the slot in the lower control arm mount for the extension to fit through while threading the nut on the bolt.

*fig. 25*

- Set the right hand unit assembly into position in the same way indexing the lower bracket with the tabs under the jounce bumper strike plate and, with the exception of using the slot for the carriage bolt in the lower bracket, install the carriage bolts in the same manner. Torque both sides of the lower bracket hardware evenly to 31 lb.-ft. making sure the tabs are still indexed under the jounce bumper strike plate. Figures 26 and 27 show the assemblies bolted into position.

**NOTE**

*Fittings should be on the outside (tire side) of the assemblies.*



Left-hand assembly shown.

*fig. 26*

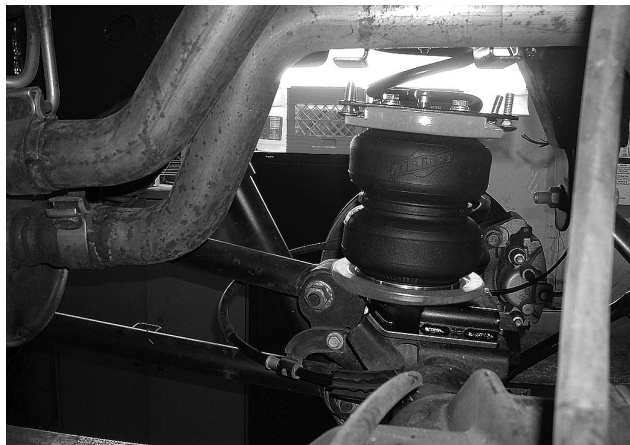

Right-hand assembly shown.

*fig. 27*

- Raise the axle back up while aligning the air spring mounting plate's carriage bolts, with the frame mounting bracket holes. Cap all carriage bolts, once in position, with 3/8" serrated lock nuts (N) and torque all the installed nuts to 31 lb.-ft. (Fig. 28).

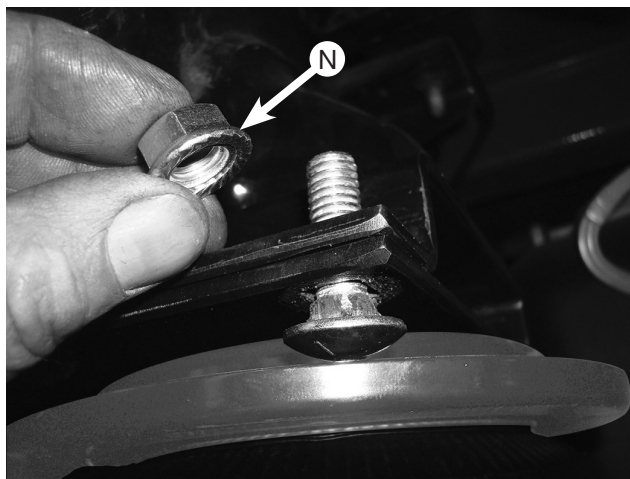

*fig. 28*

8. Left-side shown with the assembly bolted up to the frame bracket (Fig. 29).

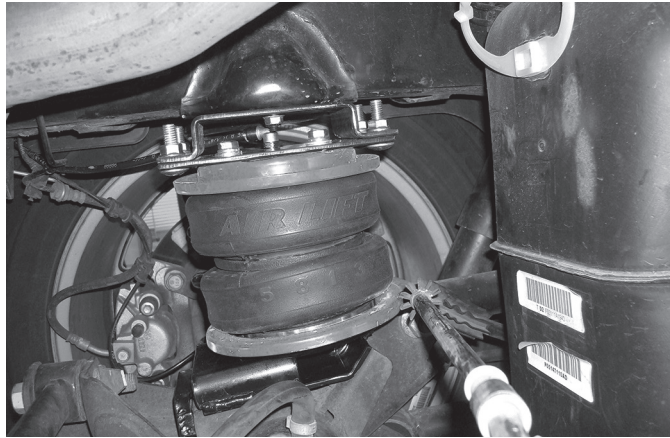
*fig. 29*

## Installing the Air Lines

1. On the passenger side only, place the provided thermal sleeve (HH) on the air line near the exhaust.
2. Remove the air line heat shield sleeve in the hose heat shield kit and install on the right side (passenger side) air line where it attaches to the fitting on the upper bracket (Fig. 30).

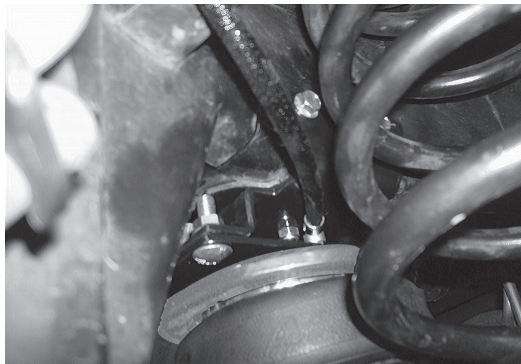

Insert the air line into the heat shield before attaching to the right-side (passenger) air spring fitting.

*fig. 30*

This section explains how to set up the air spring kit to be controlled with Schrader valves and a separate compressed air source. An on-board air compressor system allows for hassle-free control of the air springs. Learn more about Air Lift control systems at [www.airliftcompany.com/products/compressor-systems](http://www.airliftcompany.com/products/compressor-systems).

1. Choose a convenient location for mounting the inflation valves (Fig. 31). Popular locations for the inflation valve are:
  - a. The wheel well flanges
  - b. The license plate recess in bumper
  - c. Under the gas cap access door
  - d. Through the license plate

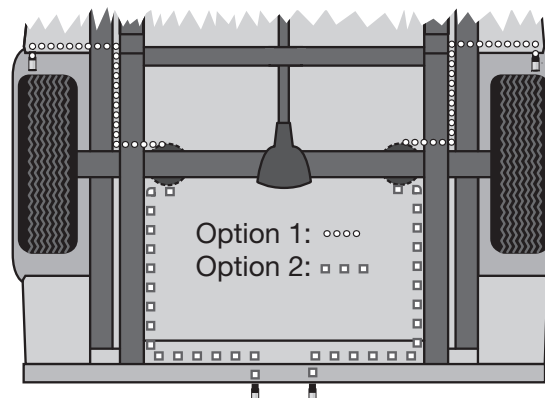
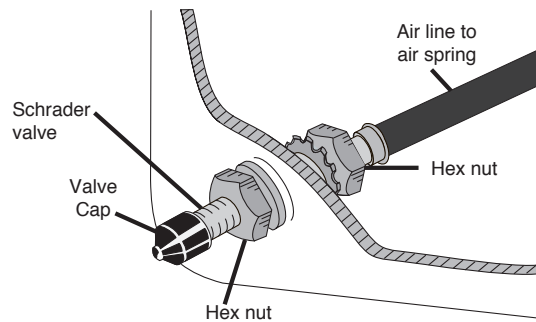

*fig. 31*



**NOTE**

Whatever the chosen location, make sure there is enough clearance around the inflation valves for an air chuck.

2. Drill 5/16" holes to install the inflation valves.
3. Cut the air line assembly in two equal lengths.
4. Place a 5/16" nut and star washer on the air valve. Leave enough of the inflation valve in front of the nut to extend through the hole and have room for the rubber washer, flat washer, and 5/16" nut and cap. There should be enough valve exposed after installation – approximately 1/2" – to easily apply a pressure gauge or an air chuck (Fig. 32).



5. Push the inflation valve through the hole and use the rubber washer, flat washer, and another 5/16" nut to secure it in place. Tighten the nuts to secure the assembly.
6. Route the air line along the frame to the fitting on the air spring. Keep AT LEAST 6" of clearance between the air line and the exhaust system. Avoid sharp bends and edges. Use zip ties to secure the air line to fixed points along the chassis. Be sure that the tie straps are tight, but do not pinch the air line. Leave at least 2" of slack to allow for any movement that might pull on the air line.
7. Cut off the air line, leaving approximately 12" of extra air line. A clean square cut will prevent leaks. Insert the air line into the air fitting. This is a push-to-connect fitting.

**TECH TIP**

Wiggle the hose back and forth while inserting to make sure the hose bottoms out in the fitting to obtain a good seal.

## TIPS FOR INSTALLING AIR LINES

When cutting air lines, use a sharp knife or a hose cutter and make clean, square cuts (Fig. 33). Do not use scissors or wire cutters because these tools may deform the air line, causing it to leak around fittings. Do not cut the lines at an angle.

Do not bend the 1/4" hose at a radius of less than 1" or bend the 3/8" hose at a radius of less than 1 1/2". Do not put side load pressure on fitting. The hose should be straight beyond the fitting for 1" before bending.

Inspect hose for scratches that run lengthwise on hose prior to installation. Contact Air Lift customer service at **(800) 248-0892** if the air line is damaged.



Go to [air-lift.co/cuttingairline](http://air-lift.co/cuttingairline) to watch a video demonstrating proper air line cutting.

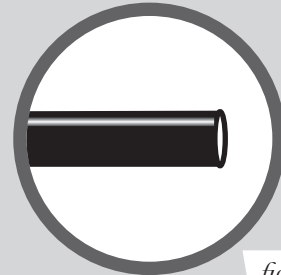
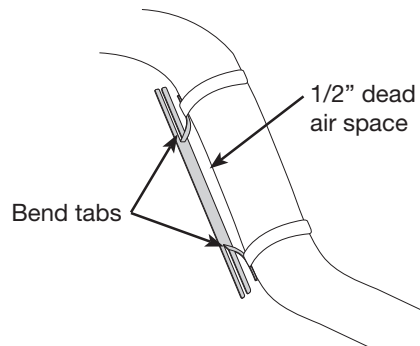

*fig. 33*



## INSTALLING THE HEAT SHIELD

1. Bend tabs to provide a dead air space between exhaust pipe and heat shield. (Fig. 34)  
Attach the heat shield to the exhaust pipe using the clamps. Bend the heat shield for maximum clearance to the air spring.



*fig. 34*

# Finished Installation Photos

1. Back view of left-side (driver) assembly (Fig. 35).



*fig. 35*

2. Back view of right-side (passenger) assembly (Fig. 36).



*fig. 36*

# Before Operating

## CHECKING FOR LEAKS

1. Inflate the air spring to 30 PSI.
2. Spray all connections and the inflation valves with a solution of 1/5 liquid dish soap and 4/5 water. Spot leaks easily by looking for bubbles in the soapy water.
3. After the test, deflate the springs to the minimum pressure required to restore the system to normal ride height. Do not deflate to lower than 5 PSI.
4. Check the air pressure again after 24 hours. A 2-4 PSI loss after initial installation is normal. Retest for leaks if the loss is more than 5 PSI.

## FIXING LEAKS

1. If there is a problem with the swivel fitting:
  - a. Check the air line connection by deflating the spring and removing the line by pulling the collar against the fitting and pulling firmly on the air line. Trim 1" off the end of the air line. Be sure the cut is clean and square (see Fig. 33). Reinsert the air line into the push-to-connect fitting.
  - b. Check the threaded connection by tightening the swivel fitting another half turn. If it still leaks, deflate the air spring, remove the fitting, and re-coat the threads with thread sealant. Reinstall by hand tightening as much as possible and then use a wrench for an additional two turns.
2. If there is a problem with the inflation valve:
  - a. Check the valve core by tightening it with a valve core tool.
  - b. Check the air line by removing the air line from the barbed type fitting. Cut the air line off a few inches in front of the fitting and use a pair of pliers or vice grips to pull/twist the air line off of the fitting.



### CAUTION

DO NOT CUT OFF THE AIR LINE COMPLETELY AS THIS WILL USUALLY NICK THE BARB AND RENDER THE FITTING USELESS.

3. If the preceding steps have not resolved the problem, call Air Lift customer service at **(800) 248-0892**.

## INSTALLATION CHECKLIST

- Clearance test** — Inflate the air springs to 75-90 PSI and make sure there is at least 1/2" clearance from anything that might rub against each sleeve. Be sure to check the tire, brakes, frame, shock absorbers and brake cables.
- Leak test before road test** — Inflate the air springs to 75-90 PSI and check all connections for leaks. All leaks must be eliminated before the vehicle is road tested.
- Heat test** — Be sure there is sufficient clearance from heat sources, at least 6" for air springs and air lines. If a heat shield was included in the kit, install it. If there is no heat shield, but one is required, call Air Lift customer service at **(800) 248-0892**.
- Fastener test** — Recheck all bolts for proper torque.
- Road test** — The vehicle should be road tested after the preceding tests. Inflate the springs to recommended driving pressures. Drive the vehicle 10 miles and recheck for clearance, loose fasteners and air leaks.
- Operating instructions** — If professionally installed, the installer should review the operating instructions with the owner. Be sure to provide the owner with all of the paperwork that came with the kit.

## POST-INSTALLATION CHECKLIST

- Overnight leak down test** — Recheck air pressure after the vehicle has been used for 24 hours. If the pressure has dropped more than 5 PSI, then there is a leak that must be fixed. Either fix the leak yourself or return to the installer for service.
- Air pressure requirements** — It is important to understand the air pressure requirements of the air spring system. Regardless of load, the air pressure should always be adjusted to maintain adequate ride height at all times while driving.
- Thirty-day or 500-mile test** — Recheck the air spring system after 30 days or 500 miles, whichever comes first. If any part shows signs of rubbing or abrasion, the source should be identified and moved, if possible. If it is not possible to relocate the cause of the abrasion, the air spring may need to be remounted. If professionally installed, the installer should be consulted. Check all fasteners for tightness.

# Product Use, Maintenance and Servicing

Minimum Recommended Pressure	Maximum Air Pressure
5 PSI	100 PSI

## MAINTENANCE GUIDELINES

### NOTE

*By following the steps below, vehicle owners will obtain the longest life and best results from their air springs.*

1. Check air pressure weekly.
2. Always maintain normal ride height. Never inflate beyond 100 PSI.
3. If the system develops an air leak, use a soapy water solution (1/5 liquid dish soap and 4/5 water) to check all air line connections and the inflation valve core before deflating and removing the air spring.



### CAUTION

FOR SAFETY AND TO PREVENT POSSIBLE DAMAGE TO THE VEHICLE, DO NOT EXCEED MAXIMUM GROSS VEHICLE WEIGHT RATING (GVWR), AS INDICATED BY THE VEHICLE MANUFACTURER. ALTHOUGH THE AIR SPRINGS ARE RATED AT A MAXIMUM INFLATION PRESSURE OF 100 PSI, THE AIR PRESSURE ACTUALLY NEEDED IS DEPENDENT ON LOAD AND GVWR.

4. Loaded vehicles require at least 25 PSI. A "loaded vehicle" refers to a vehicle with a heavy bed load, a trailer or both. Never exceed GVWR, regardless of air spring, air pressure or other load assist. The springs in this kit will support approximately 40 pounds of load (combined on both springs) for each 1 PSI of pressure. The required air pressure will vary depending on the state of the original suspension. Operating the vehicle below the minimum air spring pressure will void the Air Lift warranty.
5. When increasing load, always adjust air pressure to maintain normal ride height. Increase or decrease pressure from the system as necessary to attain normal ride height for optimal ride and handling. Remember that loads carried behind the axle (including tongue loads) require more leveling force (pressure) than those carried directly over the axle.
6. Always add air to springs in small quantities, checking the pressure frequently.
7. Should it become necessary to raise the vehicle by the frame, make sure the system is at minimum pressure (5 PSI) to reduce the tension on the suspension/ brake components. Use of on-board leveling systems do not require deflation or disconnection.
8. Periodically check the air spring system fasteners for tightness. Also, check the air springs for any signs of rubbing. Realign if necessary.
9. On occasion, give the air springs a hard spray with a garden hose to remove mud, sand, gravel or other debris.

## TUNING THE AIR PRESSURE

Pressure determination comes down to three things — level vehicle, ride comfort and stability.

### 1. Level vehicle

If the vehicle's headlights are shining into the trees or the vehicle is leaning to one side, then it is not level (Fig. 37). Raise the air pressure to correct either of these problems and level the vehicle.

### 2. Ride comfort

If the vehicle has a rough or harsh ride it may be due to either too much pressure or not enough (Fig. 38). Try different pressures to determine the best ride comfort.

### 3. Stability

Stability translates into safety and should be the priority, meaning the driver may need to sacrifice a perfectly level and comfortable ride. Stability issues include roll control, bounce, dive during braking and sponginess (Fig. 39). Tuning out these problems usually requires an increase in pressure.

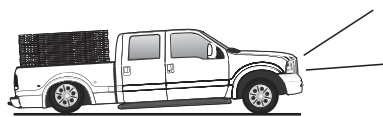

Bad headlight aim

*fig. 37*



Rough ride

*fig. 38*

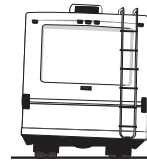

Sway and body roll

*fig. 39*

## GUIDELINES FOR ADDING AIR

1. Start with the vehicle level or slightly above.
2. When in doubt, always add air.
3. If the front of the vehicle dives while braking, increase the pressure in the front air bags, if equipped.
4. If it is ever suspected that the air bags have bottomed out, increase the pressure (Fig. 40).
5. Adjust the pressure up and down to find the best ride.
6. If the vehicle rocks and rolls, adjust the air pressure to reduce movement.
7. It may be necessary to maintain different pressures on each side of the vehicle. Loads such as water, fuel, and appliances will cause the vehicle to be heavier on one side (Fig. 41). As much as a 50 PSI difference is not uncommon.



Bottoming out

*fig. 40*

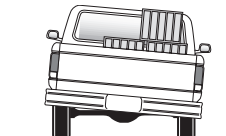

Unlevel

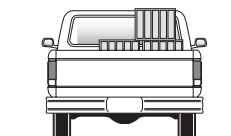

Level

*fig. 41*

# Troubleshooting Guide

PROBLEM	CAUSE	SOLUTION
System won't maintain pressure overnight.	Improperly installed air line, air line has holes or cracks.	Leak test the air line connections, the threaded connection into the air spring, and all fittings in the control system.
Air spring or air line leak.	Fitting seal or air line is compromised.	Check to make sure air lines are seated in connectors. Inspect fittings with soapy water. Trim hose or re-seal fitting. Ensure lines are cut straight.
Corner won't raise or air leak develops.	Look for a kink or fold in the air line.	Replace any air line that has been kinked.

## FREQUENTLY ASKED QUESTIONS

**Q. Will installing air springs increase the weight ratings of a vehicle?**

No. Adding air springs will not change the weight ratings (GAWR, GCWR and/or GVWR) of a vehicle. Exceeding the GVWR is dangerous and voids the Air Lift warranty.

**Q. Is it necessary to keep air in the air springs at all times and how much pressure will they need?**

For LoadLifter 5000, the recommended minimum air pressure is 5 PSI, but it can safely be run at zero air pressure unladen (no load).

**Q. Is it necessary to add a compressor system to the air springs?**

No. Air pressure can be adjusted with any type of compressor as long as it can produce sufficient pressure to service the springs. Even a bicycle tire pump can be used, but it's a lot of work.

**Q. How long should air springs last?**

If the air springs are properly installed and maintained they can last indefinitely.

**Q. Will raising the vehicle on a hoist for service work damage the air springs?**

No. The vehicle can be lifted on a hoist for short-term service work such as tire rotation or oil changes. However, if the vehicle will be on the hoist for a prolonged period of time, support the axle with jack stands in order to take the tension off of the air springs.





# Notes

# Notes

## Limited Warranty and Return Policy

Air Lift Company provides a limited lifetime warranty to the original purchaser of its Load Support products, that the products will be free from defects in workmanship and materials when used on cars and trucks as specified by Air Lift Company and under normal operating conditions, subject to the requirements and exclusions set forth in the full Limited Warranty and Return Policy that is available online at [www.airliftcompany.com/warranty](http://www.airliftcompany.com/warranty).

For additional warranty information contact Air Lift Company customer service.

## Replacement Part Information

If replacement parts are needed, contact the local dealer or call Air Lift customer service at **(800) 248-0892**. Most parts are immediately available and can be shipped the same day.

### Contact Air Lift Company customer service at (800) 248-0892 first if:

- Parts are missing from the kit.
- Need technical assistance on installation or operation.
- Broken or defective parts in the kit.
- Wrong parts in the kit.
- Have a warranty claim or question.

### Contact the retailer where the kit was purchased:

- If it is necessary to return or exchange the kit for any reason.
- If there is a problem with shipping if shipped from the retailer.
- If there is a problem with the price.

## Contact Information

<b>Mailing address</b>	P.O. Box 80167 Lansing, MI 48908-0167
<b>Shipping address for returns</b>	2727 Snow Road Lansing, MI 48917
<b>Phone</b>	Toll free: (800) 248-0892 International: (517) 322-2144
<b>Email</b>	<a href="mailto:service@airliftcompany.com">service@airliftcompany.com</a>
<b>Web address</b>	<a href="http://www.airliftcompany.com">www.airliftcompany.com</a>

## **Need Help?**

**Contact Air Lift Company customer service department by calling (800) 248-0892.**

**For calls from outside the USA or Canada, dial (517) 322-2144.**



*Thank you for purchasing Air Lift products — the professional installer's choice!*

---

Air Lift Company • 2727 Snow Road • Lansing, MI 48917 or P.O. Box 80167 • Lansing, MI 48908-0167  
Toll Free (800) 248-0892 • Local (517) 322-2144 • Fax (517) 322-0240 • [www.airliftcompany.com](http://www.airliftcompany.com)

Printed in the USA  
JJC-0217