

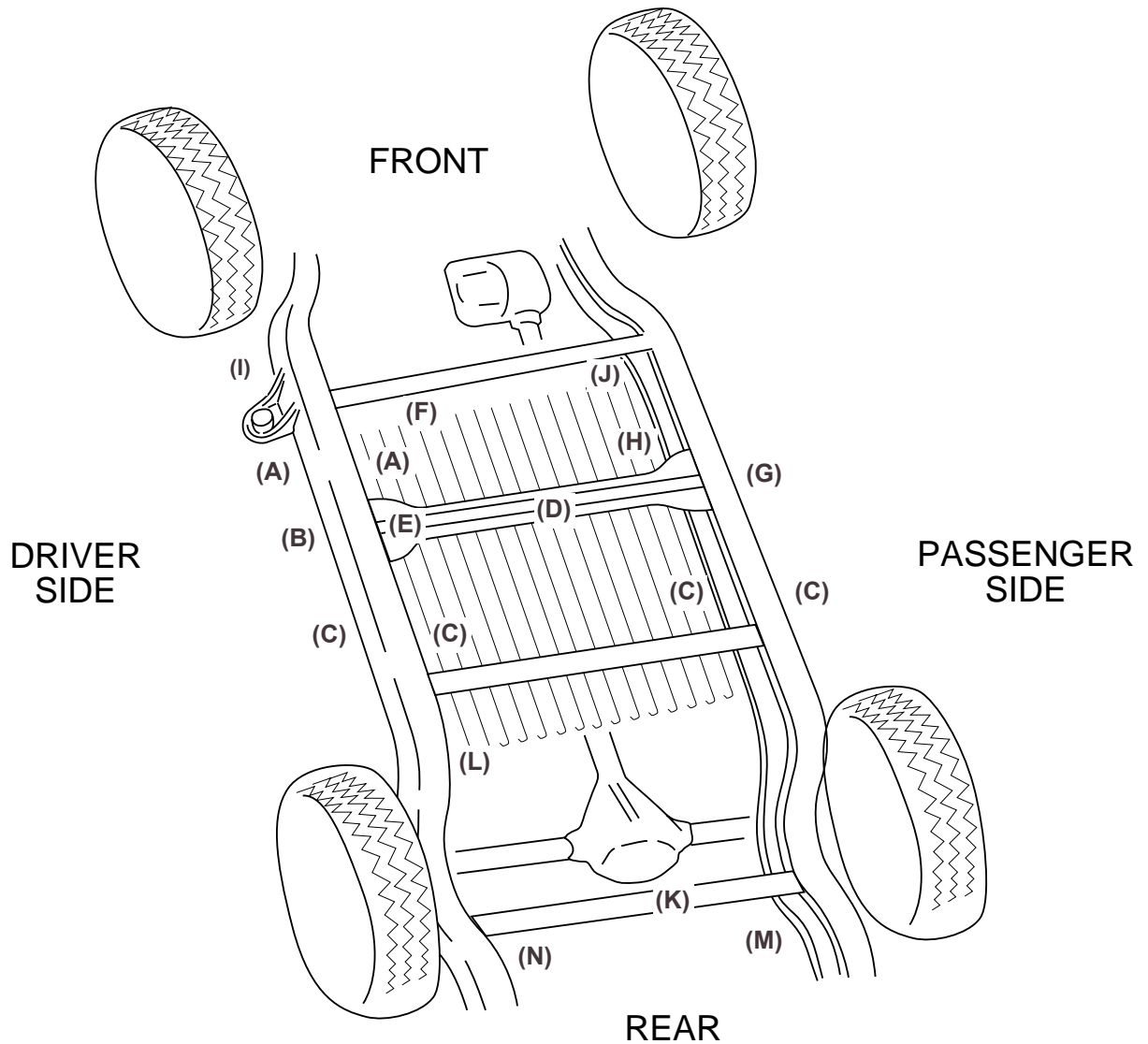

RECOMMENDED COMPRESSOR LOCATIONS

SB-126
(04811)
ECN2613



- (A) DRIVER SIDE, IN OR OUTSIDE FRAME RAIL
- (B) DRIVER SIDE, OUTSIDE FRAME RAIL
- (C) DRIVER OR PASSENGER SIDE, IN OR OUTSIDE FRAME RAIL
- (D) MIDDLE CROSSMEMBER
- (E) DRIVER SIDE, CROSSMEMBER
- (F) DRIVER SIDE, FLOOR PAN UNDER DRIVER SEAT
- (G) PASSENGER SIDE, OUTSIDE FRAME RAIL
- (H) PASSENGER SIDE, INSIDE FRAME RAIL
- (I) BODY SUPPORT, BEHIND FRONT DRIVER SIDE TIRE
- (J) PASSENGER SIDE, INSIDE FRAME RAIL, BEHIND TRANSFER CASE CROSS MEMBER
- (K) CROSSMEMBER BEHIND REAR AXLE HOUSING
- (L) DRIVER SIDE, INSIDE FRAME RAIL
- (M) FLOOR PAN, BEHIND REAR AXLE HOUSING, NEXT TO GAS TANK
- (N) REAR PANHARD ROD CROSS MEMBER

Following are the recommended compressor locations for most light trucks, vans and sport utility vehicles. If your vehicle is not listed, select a location where the compressor is reasonably well protected from the elements. Avoid high heat environments as well. Avoid mounting under the hood. You must also check to be sure that Harness #2 will reach the compressor and connect to Harness #1. The compressor can be mounted in any position - vertical, upside down, sideways, etc. (Figure 5, of the instruction manual).

ACURA

SLX(A)

CHEVY/GMC/OLDSMOBILE

S-10 PICK-UP except '98 2WD(A)
 S-10 PICK-UP '98 2WD ONLY(C)
 S-10 BLAZER, S-15 JIMMY, BRAVADA(A)
 GEO TRACKER(B)
 SUBURBAN(C)
 TAHOE, YUKON, BLAZER, JIMMY (Full Size)(C)
 C/K PICK-UP ALL MODELS(C)
 ASTRO, SAFARI(D)
 LUMINA SUV, SILHOUETTE, TRANSPORT(B)
 G-VAN (Full Size) except '98(E)
 G-VAN (Full Size) '98 ONLY(B or C)
 VENTURE(B)

CHRYSLER/DODGE/PLYMOUTH VANS

TOWN and COUNTRY ALL MODELS(F)
 CARAVAN ALL MODELS(F)
 VOYAGER ALL MODELS(F)
 FULL SIZE VAN(D)

DODGE

94-UP FULL SIZE PICK-UP(G)
 69-93 FULL SIZE PICK-UP(C)
 RAMCHARGER(C)
 DAKOTA(C)
 RAIDER(C)

FORD

EXPEDITION(G)
 EXPLORER(G)
 RANGER except '98(A)
 RANGER '98-UP 2WD ONLY(G)
 RANGER '98-UP 4WD ONLY(C)
 FULL SIZE PICK-UP(A,C ORG)
 BRONCO II(A)
 BRONCO (Full Size)(A)
 WINDSTAR(B)
 AEROSTAR(B)
 FULL SIZE VANS(A)

INFINITY

QX4(N)

ISUZU

ALL MODELS(A)

JEEP

WRANGLER(B)
 CHEROKEE(B)
 GRAND WAGONEER, GRAND CHEROKEE(F)

LEXUS

LX 450(B)

MAZDA

72-94 PICK-UP(H)
 94-96 PICK-UP(A)
 NAVAJO(G)
 MPV VAN(I)

MERCURY

MOUNTAINEER(G)
 VILLAGER(B)

MITSUBISHI

MONTERO(B)
 PICK-UP(A)

NISSAN

PICK-UP OR FRONTIER(C)
 96-97 PATHFINDER(N)
 87-95 PATHFINDER(J)
 QUEST(I)

SUZUKI

SIDEKICK(B)
 X-90(G)

TOYOTA

PICK-UP(C)
 RAV4(K)
 4-RUNNER(L)
 LANDCRUISER(B)
 PREVIA(M)
 SIENNA(G)

VOLKSWAGEN

VAN(D)

